



Research Paper / Makale

Investigating on Environmental Effects of Different Combi Boilers Using LPG Fuel

Halil İbrahim VARIYENLİ¹, Faraz AFSHARI², Ataollah KHANLARI³

¹Gazi University, Technology Faculty, Energy Systems Engineering, Teknikokullar, 06500, Ankara, Turkey,

²Erzurum Technical University, Department of Mechanical Engineering, Erzurum, Turkey

³University of Turkish Aeronautical Association, Mechanical Engineering, 06790, Ankara, Turkey.

halily@gazi.edu.tr

Received/Geliş: 13.06.2019

Accepted/Kabul: 05.09.2019

Abstract: Space heating and hot water supplying are usually done by utilizing combi boilers. Various kinds of combi boilers are available. In the last years condensing type combi boilers have been introduced that have high efficiency in comparison to conventional one. In the present study the impact of combi boiler type on pollutant gas emissions was experimentally investigated. Three various combi boiler including condensing, full condensing and conventional type combi boilers have been utilized in the experiments. Moreover, the experiments have been conducted in various outlet hot water temperatures to determine the effect of temperature. The achieved findings indicated that in all temperatures utilizing condensing and full condensing combi boilers decreased NO, NO_x and SO₂, gas emissions considerably.

Keywords: Combi boiler, heating, condensing, pollutant gas emissions.

LPG Yakıt Kullanarak Farklı Kombilerin Çevresel Etkilerinin Araştırılması

Öz: Binaların ısıtılması ve sıcak su temini genellikle kombiler yardımıyla yapılmaktadır. Kombilerin farklı tipleri mevcuttur. Son yıllarda konvansiyonel kombilere göre yüksek verimli yoğuşmalı tip kombiler piyasaya sürülmüştür. Bu çalışmada, kombi tipinin kirletici gaz emisyonu üzerindeki etkisi deneysel olarak incelenmiştir. Deneysel yoğuşmalı, tam yoğuşmalı ve konvansiyonel tip kombi olarak üç farklı kombi kullanılmıştır. Ayrıca, sıcaklığın etkisini belirlemek için deneyler çeşitli sıcak su sıcaklıklarında gerçekleştirilmiştir. Elde edilen sonuçlara göre, yoğuşmalı ve tam yoğuşmalı kombiler tüm sıcaklıklarda NO, NO_x ve SO₂, gaz emisyonlarını önemli ölçüde azaltmıştır.

Anahtar kelimeler: Kombi, ısıtma, yoğuşmalı, gaz emisyonu.

1. Introduction

By increasing energy demand renewable energy resources and efficient energy systems gain importance day by day. Also, the amount of pollutant gas emissions from energy conversion systems is another significant issue that should be taken in consideration. A major part of total energy consumption is used in buildings and a big part of this energy is used for hot water providing and space heating [1-3]. Space heating and hot water providing is usually supplied by combi boilers in residential buildings. In the last years condensing type combi boilers have been introduced that have higher thermal performance in comparison to conventional combi boilers. Different heating systems and combi boilers have been studied by various researchers [4-6]. In some studies, nanofluid was used to enhance the thermal performance of systems like heat pipe and combi boiler [7-10]. In addition, turbulators have been used in heat exchanger to improve the efficiency [11]. The

How to cite this article

Variyenli, H.İ., Afshari, F., Khanlari, A., "Investigating on Environmental Effects of Different Combi Boilers Using LPG Fuel" El-Cezeri Journal of Science and Engineering, 2019, 6(3); 681-690.

Bu makaleye atıf yapmak için

Variyenli, H.İ., Afshari, F., Khanlari, A., "LPG Yakıt Kullanarak Farklı Kombilerin Çevresel Etkilerinin Araştırılması" El-Cezeri Fen ve Mühendislik Dergisi 2019, 6(3); 681-690.

environmental effects of heating systems as an important issue have been studied by different investigators. The environmental impact of combined heating system were studied by Haichao et al. [12]. They used a model to analyze greenhouse gas emissions of heating systems. Their findings showed the potential of combined systems to decrease CO₂ emission. In another study the energy and environmental impact of domestic heating systems from 1999 to 2010 in Italy investigated by Aste et al. [13]. They indicated that pollutant emissions reduction and energy saving can be achieved by using new boiler technologies. Atmaca et al. investigated transient behavior of conventional and condensing type combi boilers [14]. They said that condensing type combi boiler has priority in terms of thermal performance and comfort. Vignali investigated the environmental impact of two different combi boilers in three climatic regions in Italy [15]. Their findings showed that condensing type combi boiler has 23% lower environmental effect in comparison to conventional combi boiler. Bălănescu and Homutescu experimentally studied the performance of condensing boiler [16]. Their results indicated that maximum 17.5% energy saving can be obtained by using condensing type boiler.

In this study, the effect of conventional, condensing and full condensing combi boilers on pollutant gas emissions has been experimentally analyzed. In the experiments liquefied petroleum gas (LPG) was used to run combi boilers. Also, the effects of the intended temperature on pollutant gas emissions was investigated.

2. Material and Methods

In this study, three different combi boilers including; conventional type combi boiler, condensing type combi boiler and full condensing type combi boiler which produced by Buderus company have been utilized in the experiments.

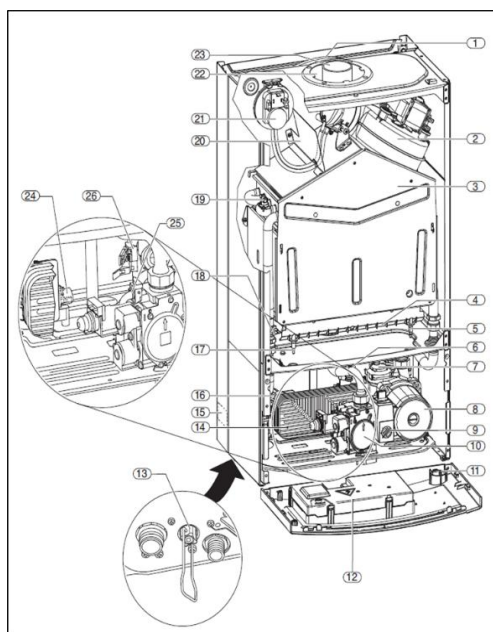

Figure 1. Conventional combi boiler components [17];

The components are given as 1. Expansion vessel 2. Fan, 3. Combustion chamber, 4. Burner, 5. Ignition electrode, 6. Safety valve, 7. Inlet air vent, 8. Circulation pump, 9. Pump speed switch, 10. Gas armature, 11. Pressure gauge, 12. Control panel, 13. System filling device, 14. Plate heat exchanger, 15. Type label, 16. Pressure controller, 17. Detection electrode, 18. Water temperature sensor, 19. Safety thermostat, 20. Draught diverter, 21. Differential pressure switch, 22. Combustion air intake, 23. Exhaust gas outlet, 24. Temperature sensor, 25. Safety valve, 26. Flowmeter.

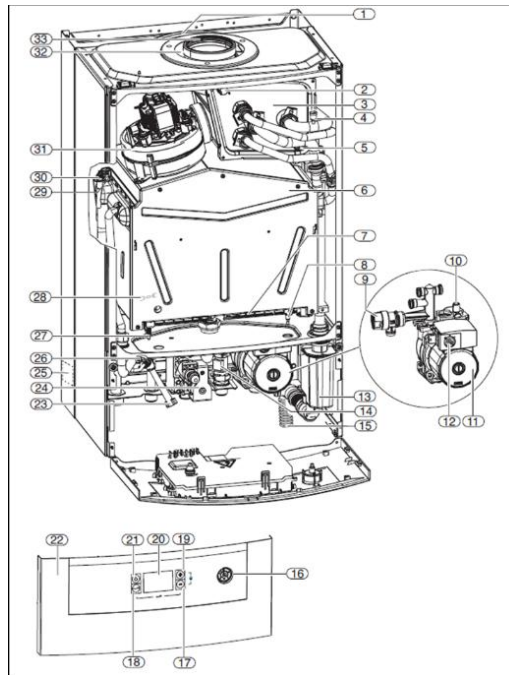

Figure 2. Condensing combi boiler [17].

In this figure, 1. Expansion vessel, 2. Waste gas temperature controller, 3. Heat exchanger, 4. Manual air vent, 5. Condensate sensor, 6. Combustion chamber, 7. Burner, 8. Electrodes, 9. Safety valve, 10. Automatic air blower, 11. Circulation pump, 12. Pump speed variator, 13. Condensate trap, 14. Flowmeter, 15. Condensate discharge, 16. Pressure gauge, 17. Control key, 18. Mode, 19. Control key, 20. Display, 21. Stand-by mode, 22. Front panel, 23. System filling device, 24. Gas valve, 25. Control lid, 26. Temperature sensor, 27. Ignition electrode, 28. Combustion chamber, 29. Temperature sensor, 30. Temperature controller, 31. Fan, 32. Combustion air intake, 33. Waste gas duct.

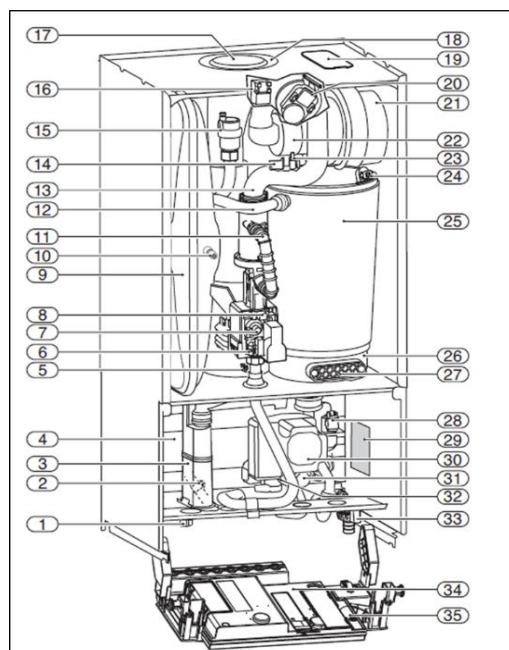

Figure 3. Full condensing combi boiler [17].

The components in this boiler as 1. System filling device, 2. Temperature sensor, 3. Condensate drain, 4. Plate heat exchanger, 5. Waste gas temperature controller, 6. Gas pressure controller, 7.

Maximum gas regulator, 8. Minimum gas regulator, 9. Expansion vessel, 10. Nitrogen filling valve, 11. Gas pipe, 12. Heating circuit outlet line, 13. Suction pipe, 14. Temperature sensor, 15. Inlet air vent, 16. Igniter, 17. Waste gas duct, 18. Combustion air intake, 19. Control lid, 20. Differential pressure switch, 21. Fan, 22. Waste gas backflow mixing unit, 23. Electrode Set, 24. Safety thermostat, 25. Heat block, 26. Condensate trap, 27. Control lid, 28. 3-way valve, 29. Type label, 30. Circulation pump, 31. Safety valve, 32. Flowmeter, 33. filling and drain tap, 34. Control panel, 35. Pressure gauge

All of the selected combi boilers have the same heating capacity (24 kW) and could be run by both liquefied petroleum gas (LPG) and natural gas. The main component of conventional type combi boiler is shown in Fig. 1. The main component of condensing type combi boiler is shown in Fig. 2. In the condensing combi boiler thermal energy recovered from combustion gases. In the condensing combi boiler, a further heat exchanger is utilized to recover energy from combustion gases. Also, the main component of full condensing combi boiler is shown in Fig. 3. In the full condensing combi boiler condensation phenomena occur in the combustion chamber. This procedure causes to enhance thermal performance of combi boiler.



Figure 4. ECOM J2KN emissions analyzer



Figure 5. Measuring pollutant gas emissions by ECOM J2KN analyzer

In this study pollutant gas emissions including SO₂, NO and NO_x from three different combi boilers have been experimentally analyzed. In this regard, ECOM J2KN emissions analyzer has been utilized to determine the amount of pollutant gases including SO₂, NO and NO_x. Fig. 4 shows ECOM J2KN emissions analyzer which was used in the analysis. In the experiments the temperature of hot water was adjusted in 5 different temperatures (40°C, 45°C, 50°C, 55°C and 60°C) to determine the effect of working temperature on pollutant gas emission. Each experiment was repeated three times to obtain more accurate results. Fig. 5 shows gas emission measuring in combi boiler by using ECOM J2KN emissions analyzer. Technical specifications of ECOM J2KN gas analyzer are presented in Table 1.

Table 1. Technical specifications of ECOM J2KN gas analyzer

MEASUREMENT (KEY)	RANGE	ACCURACY	RESOLUTION
Oxygen (O)	0-21% vol.	± 2% Measured	0.1% vol.
Carbon Monoxide (C)	0-4,000 ppm	± 2% Measured	1 ppm
Carbon Monoxide (V)	0-40,000 ppm	± 2% Measured	1 ppm
Nitric Oxide (N)	0-4,000 ppm	± 2% Measured	1 ppm
Nitric Oxide (.N)	0-400 ppm	± 2% Measured	0.1 ppm
Nitrogen Dioxide (X)	0-500 ppm	± 2% Measured	1 ppm
Nitrogen Dioxide (.X)	0-50 ppm	± 2% Measured	0.1 ppm
Sulfur Dioxide (S)	0-5,000 ppm	± 2% Measured	1 ppm
Combustibles (H)	0-6.00 % vol.	± 2% Measured	0.01% vol
Gas Temperature	32-1800 F	± 2% Measured	1 deg F
Ambient Temperature	0-250 F	± 2% Measured	1 deg F
Draft / Pressure	± 40" H ₂ O	± 2% Measured	0.1% H ₂ O
O ₂ Correction	0-20% Oxygen		
Smoke Scale	0-9		
Carbon Dioxide CO ₂	0-CO ₂ max of fuel	Calculated	
Efficiency	0-99.9%	Calculated	
Excess Air (Lambda)	1-infinity	Calculated	

3. Results

The effects of condensing and full condensing type combi boilers on energy saving is clear. However, the environmental impact of combi boilers is important. The main aim of this study is to determine the amount of SO₂, NO and NO_x pollutant gases in the flue gas. SO₂ gas emission in various temperatures for different combi boilers is given in Fig. 6.

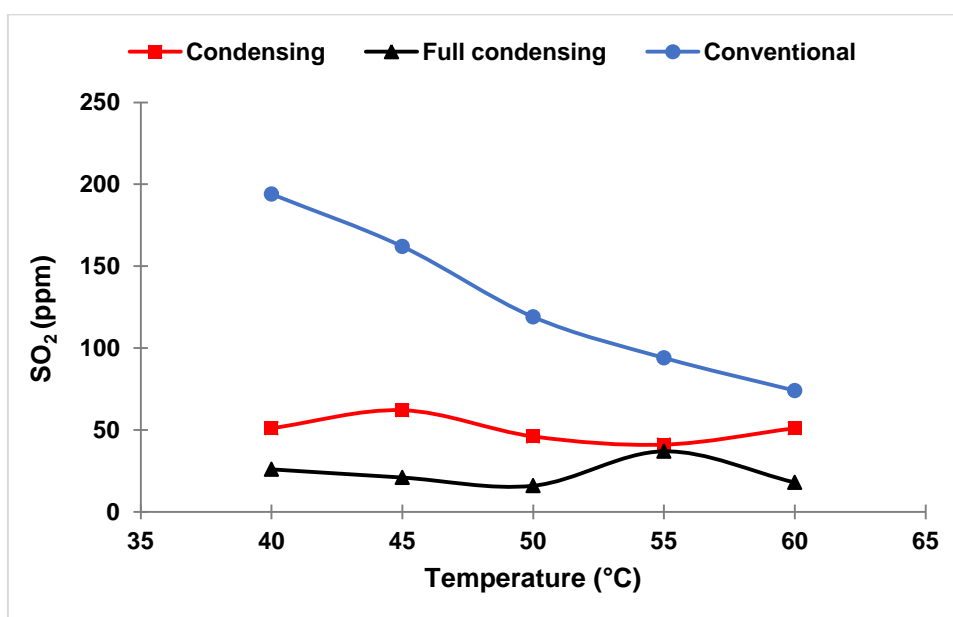

Figure 6. SO₂ gas emission in different combi boilers

As it can be seen in Fig. 6 the amount of SO₂ gas emission in conventional combi boiler is higher than condensing and full condensing type boilers. In conventional combi boiler, the amount of SO₂ gas emission decreases with increasing hot water temperature. But in condensing and full condensing combi boilers, the amount of SO₂ gas emission slightly decreases with increasing the temperature and then increases.

Figure 7 shows the variation of NO gas emission via temperature in various combi boilers. In the conventional combi boiler, NO gas emission increases with increasing working temperature and then continues at a constant value. However, in the condensing and full condensing combi boilers NO gas emission increases with increasing working temperature.

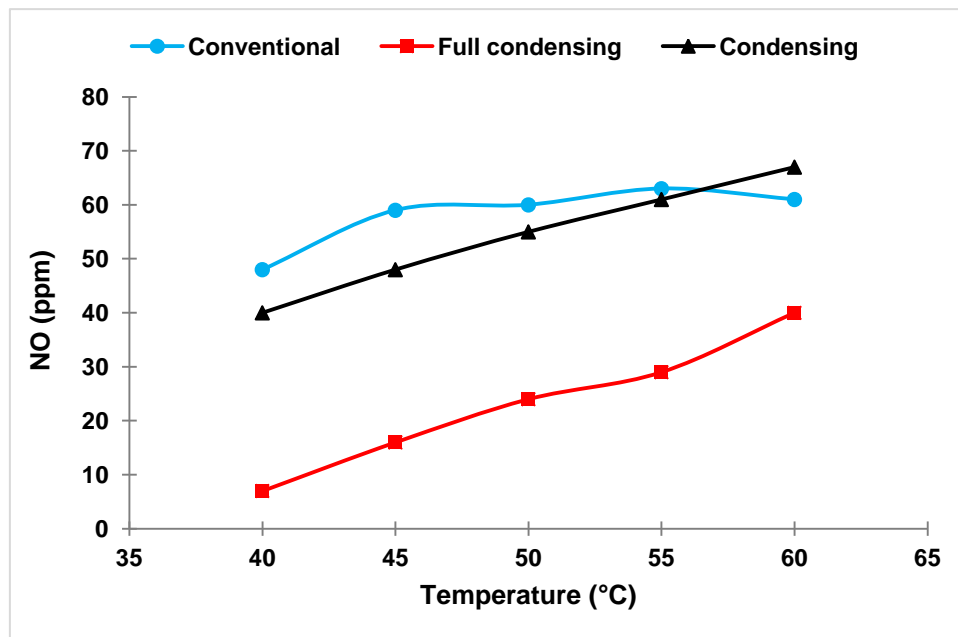

Figure 7. NO gas emission in different combi boilers

Finally, NO_x gas emission variation with temperature in different combi boilers is given in Fig. 8. In the conventional combi boiler, NO_x gas emission increases with increasing working temperature and then continues at a constant value.

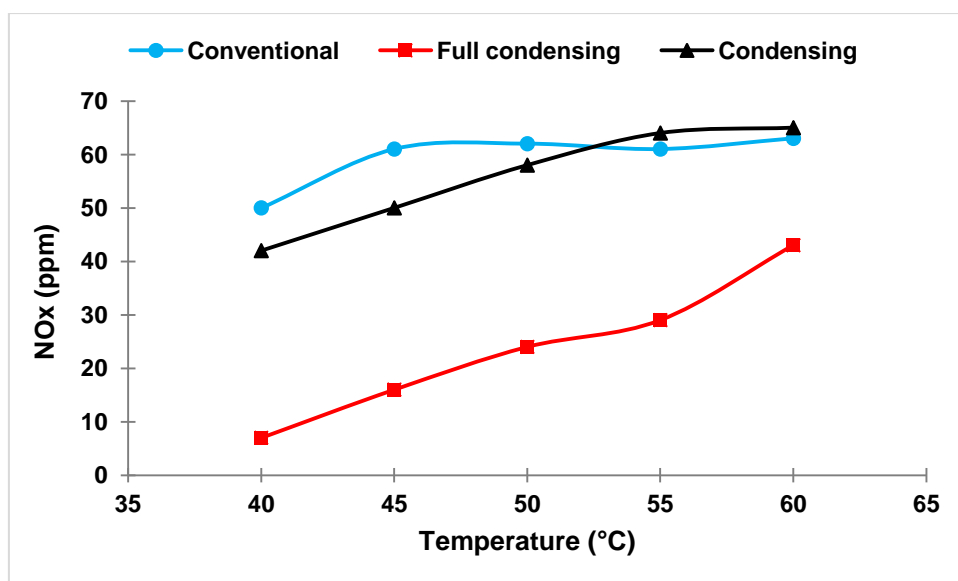

Figure 8. NO_x gas emission in different combi boilers

However, in the condensing and full condensing combi boilers NO_x gas emission increases with increasing working temperature. Fig. 10-13 show the flue gas temperature in different working temperatures for three various combi boilers. Flue gas temperature in the conventional combi boiler has the highest value and in full condensing type combi boiler has the lowest value in all working temperatures. In the condensing type combi boiler, an additional heat exchanger was mounted to the combi and recover the sensible and latent heat in the flue gas.

The result of recovering available heat in the flue gas cause to decrease in the temperature of outlet flue gas of the combi boiler. Full condensing type combi boiler has lower flue gas outlet temperature in comparison with condensing combi boiler because condensing phenomena take place in the combustion chamber. Synchronous realization of combustion and condensation processes in the combustion chamber lead to more reduction in flue gas temperature and improve efficiency of combi boiler. Eventually, low energy is needed to obtain the same thermal performance by utilizing condensing technology.

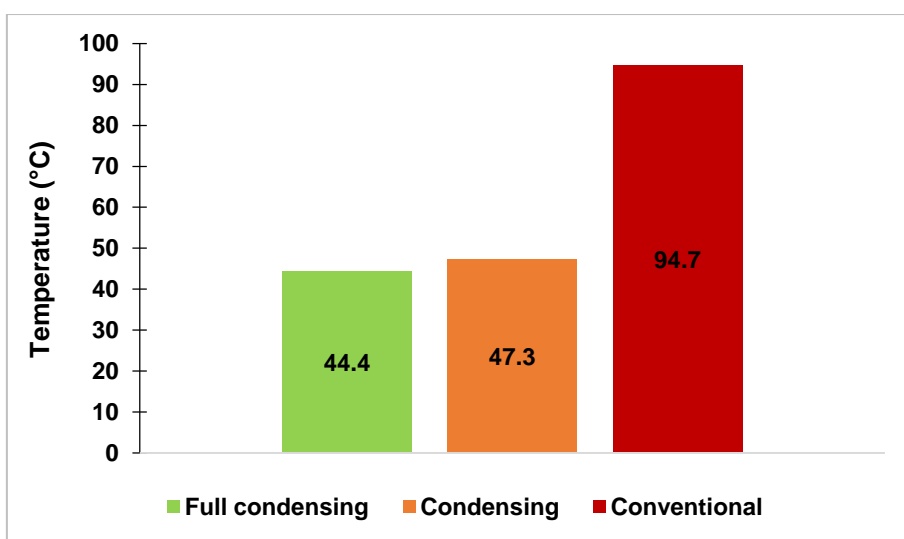

Figure 9. Flue gas temperature for 40°C outlet hot water

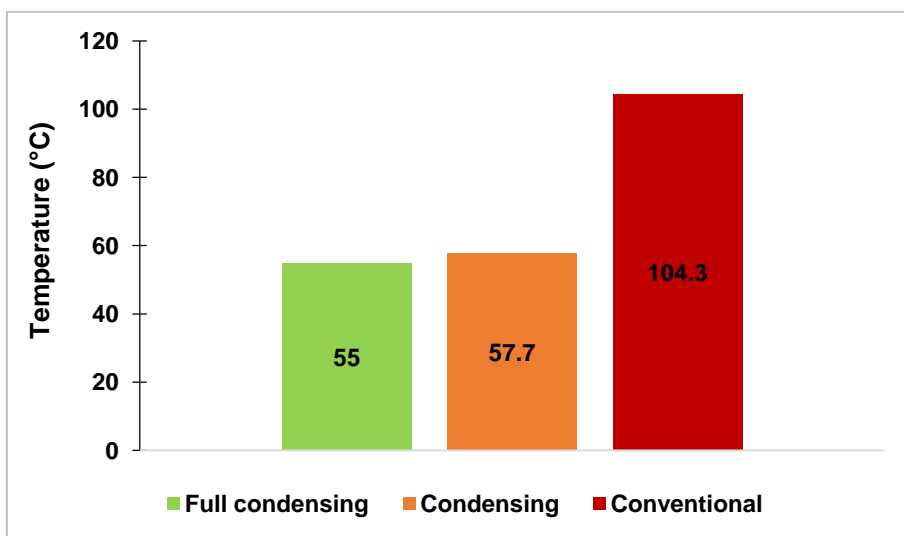

Figure 10. Flue gas temperature for 45°C outlet hot water

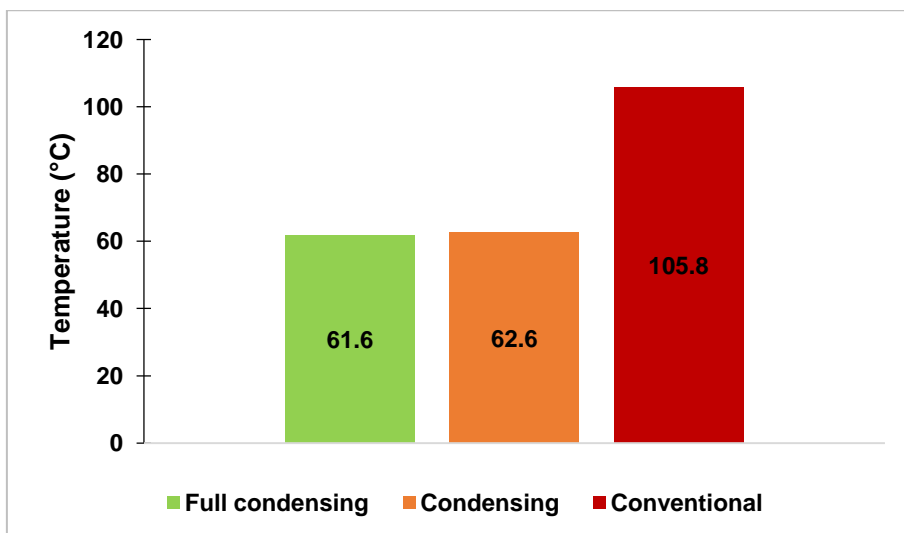

Figure 11. Flue gas temperature for 50°C outlet hot water

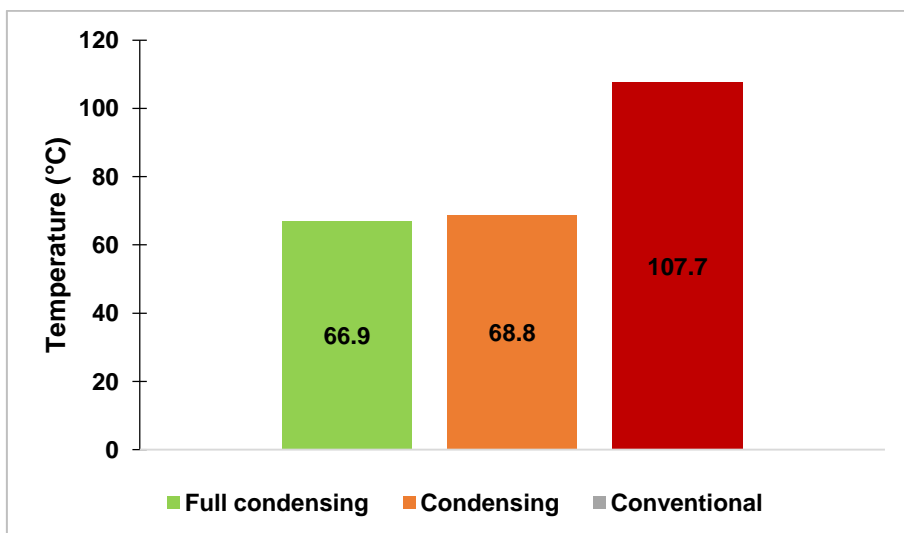

Figure 12. Flue gas temperature for 55°C outlet hot water

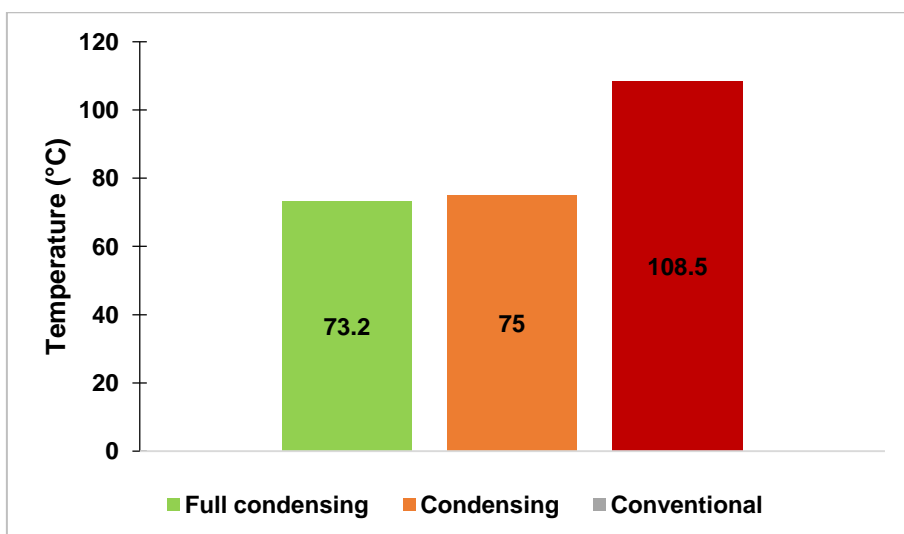

Figure 13. Flue gas temperature for 60°C outlet hot water

4. Conclusion

Combi-boilers are domestic heating boilers which can be mounted on kitchen or bathroom wall to provide both heating and domestic hot water.

In this experimental study the influence of combi boiler type on pollutant gas emissions was analyzed.

In this regard conventional, condensing and full condensing combi boilers were selected for the experiments. The emissions analyzer was used to measure NO, NO_x, SO₂ values of the under test combi devices. The analysis were conducted in various hot water outlet temperatures to illustrate the effect of temperature. Generally, it could be indicated that using condensing and full condensing type combi boilers could decrease pollutant gas emissions in comparison to conventional one.

References

- [1]. Omer, A.M., "Energy, environment and sustainable development. Renewable and sustainable energy reviews", 2008, 12(9): 2265-2300. doi.org/10.1016/j.rser.2007.05.001.
- [2]. Afshari, F., Comakli, O., Karagoz, S., Zavaragh, H.G., "A thermodynamic comparison between heat pump and refrigeration device using several refrigerants", Energy and Buildings, 2018, 168: 272-283. doi.org/10.1016/j.enbuild.2018.03.037.
- [3]. Khanlari, A., Ay, İ., "A numerical study on determination of the optimal hole diameter and pitch value for the unglazed transpired solar collectors", Journal of Politeknik, 2019, 22 (1): 163-168. doi.org/10.2339/politeknik.477094.
- [4]. Özdemir, M.B., Ergun, M.E., "Experimental and numerical investigations of thermal performance of Al₂O₃/water nanofluid for a combi boiler with double heat exchangers", International Journal of Numerical Methods for Heat & Fluid Flow, 29 (4): 1300-1321. doi.org/10.1108/HFF-05-2018-0189.
- [5]. Lomas, K.J., Oliveira, S., Warren, P., Haines, V.J., Chatterton, T., Beizae, A., Prestwood, E., Gething, B., "Do domestic heating controls save energy? A review of the evidence", Renewable and Sustainable Energy Reviews, 2018, 93: 52-75. doi.org/10.1016/j.rser.2018.05.002.
- [6]. Casanovas-Rubio, M.D.M., Armengou, J., "Decision-making tool for the optimal selection of a domestic water-heating system considering economic, environmental and social criteria: Application to Barcelona (Spain)", Renewable and Sustainable Energy Reviews, 2018, 91: 741-753. doi.org/10.1016/j.rser.2018.04.040.
- [7]. Sözen A., Öztürk, A., Özalp, M., Çiftçi, E., "Influences of alumina and fly ash nanofluid usage on the performance of recuperator including heat pipe bundle", International journal of Environmental Science and Technology, 16 (9): 5095-5100. doi: 10.1007/s13762-018-1832-6.
- [8]. Sözen A., Khanlari, A., Çiftçi, E., "Experimental and numerical investigation of nanofluid usage in a plate heat exchanger for performance improvement", Int. Journal of Renewable Energy Development, 2019, 8 (1): 27-32. doi.org/10.14710/ijred.8.1.27-32.
- [9]. Khanlari, A., Sözen, A., Variyenli, H.İ., "Simulation and experimental analysis of heat transfer characteristics in the plate type heat exchangers using TiO₂/water nanofluid", International Journal of Numerical Methods for Heat & Fluid Flow, 29 (4): 1343-1362. doi 10.1108/HFF-05-2018-0191.
- [10]. Khanlari, A., Sözen, A., Variyenli, H.İ., Gürü, M., "Comparison between heat transfer characteristics of TiO₂/deionized water and kaolin/deionized water nanofluids in the plate heat exchanger", Heat Transfer Research, 2019, 50 (5): 435-450. doi: 10.1615/HeatTransRes.2018026288.
- [11]. Afshari, F., Zavaragh, H.G., Di Nicola, G., "Numerical analysis of ball-type turbulators in tube heat exchangers with computational fluid dynamic simulations", International journal of Environmental Science and Technology, 16 (7): 3771-3780. doi: 10.1007/s13762-018-2012-4.

- [12]. Haichao, W., Jiao, W., Lahdelma, R., Pinghua, R., Shuhui, Z., “Atmospheric environmental impact assessment of a combined district heating system”, *Building and Environment*, 2013, 64: 200-212. doi.org/10.1016/j.buildenv.2013.02.011.
- [13]. Aste, N., Adhikari, R.S., Compostella, J., Del Pero, C., “Energy and environmental impact of domestic heating in Italy: Evaluation of national NO_x emissions”, *Energy Policy*, 2013, 53: 353-360. doi.org/10.1016/j.enpol.2012.10.064.
- [14]. Atmaca, A.U., Erek, A., Altay, H.M., “Investigation of transient behaviour of combi boiler type appliances for domestic hot water”, *Applied Thermal Engineering*, 2015, 82: 129-140. doi.org/10.1016/j.applthermaleng.2015.02.051.
- [15]. Vignali, G., “Environmental assessment of domestic boilers: A comparison of condensing and traditional technology using life cycle assessment methodology”, *Journal of Cleaner Production*, 2017, 142: 2493-2508. doi.org/10.1016/j.jclepro.2016.11.025.
- [16]. Bălănescu, D.T., Homutescu, V.M., “Experimental investigation on performance of a condensing boiler and economic evaluation in real operating conditions”, *Applied Thermal Engineering*, 2018, 143: 48-58. doi.org/10.1016/j.applthermaleng.2018.07.082.
- [17]. Adagaz Natural Gas Heating and Cooling Systems- Buderus Kombiler (www.buderus.com)